

Permanent Holding Magnet

9

Product group

G MP ... B01 G ZZ

Function

- High holding force
- Increasing force vs. stroke characteristic
- Closed circuit principle:
 - De-energized: max. holding force through integrated permanent solenoid
 - Energized: holding force is compensated

Construction

- Mounting via central thread on the front side
- Insulation materials of the excitation winding correspond to thermal class B
- Electrical connection via free flexible lead ends
- Protection class according to DIN VDE/DIN EN 60529 IP 00

Application examples

- Mechanical engineering and fixture construction, conveyor technology, door holding systems
- Interlocking of all sorts

Options

- Protection class IP 65 on request

Standards

- Design and testing according to DIN VDE 0580
- Quality management to ISO 9001

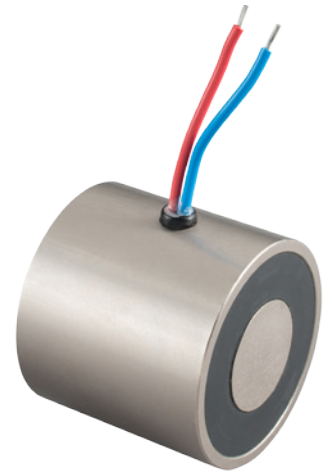

Fig. 1: Type G MP X 050 X00 B01

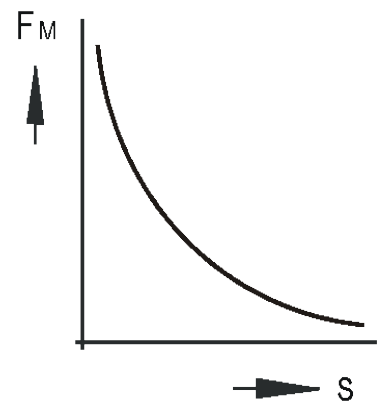

Fig. 2: Force vs stroke characteristic

Technical data

G MP X ... X00 B01	025	030	035	050
Operating mode ED	S2 (2 s)	S2 (2 s)	S2 (2 s)	S2 (2 s)
Max. duty cycle ⁴⁾	S3 15%	S3 30%	S3 25%	S3 25%
Rated power P ₂₀ (W)	16	10	16	31
Magnetic forces using the specimen* and stroke 0 mm				
Holding force F _M (N)	140	240	320	800
¹⁾ Residual holding force F _{MR} bei U _N (N)	18	30	35	100
²⁾ Residual holding force F _{MR} bei I _{ab} = konst. (N)	6	8	8	10
Magnetic forces using armature type GZZE (fig. 5) and stroke 0 mm ³⁾				
Holding force F _M (N)	110	190	260	640
¹⁾ Residual holding force F _{MR} bei U _N (N)	15	24	28	80
²⁾ Residual holding force F _{MR} bei I _{ab} = konst. (N)	5	7	7	8
I _{ab} = konst. (A)	0,55	0,35	0,5	1,1
Reference temperature θ ₁₃ (°C)	35	35	35	35
Solenoid weight mM (kg)	0,053	0,106	0,200	0,577
Test specimen diameter (mm)	25	30	35	50
* Test specimen thickness (mm)	3	4	5	6

* The test specimen is made of 9 S Mn. The pole surface is plane and polished and has a roughness of 15 µm max. With smaller specimen thickness or bad surface quality the magnetic force decreases. The use of materials having a different permeability may lead to considerable deviations regarding the holding force.

- 1) The external return forces have to be sufficiently higher than the residual force.
- 2) In order to eliminate the influence of the coil resistance (dependent on the temperature rise) on the residual force we recommend you to drive the solenoid with constant current (see also fig. 3).
- 3) When using the armature GZZE the magnetic forces are reduced due to the layer thickness of the electroplating.
- 4) The devices are designed for short-time duty S2. In principle, an operation with the indicated admissible max. duty cycle is possible. It should be noted that the residual holding force changes by heating (see also ²⁾).

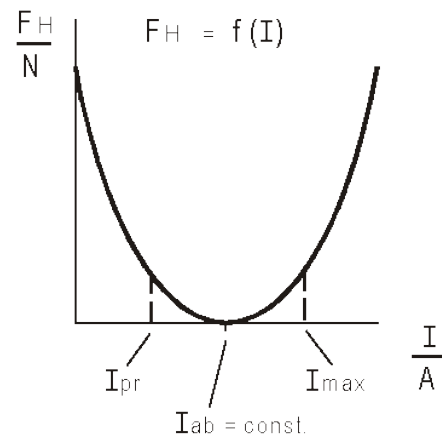

Fig. 3: characteristic

Notes on the tables

Due to natural dispersion the force values may deviate by $\pm 10\%$ from the values indicated in the tables.

Rated voltage

Rated voltage is ≈ 24 V. An adaptation of the exciter coil to a rated voltage less than ≈ 60 V is possible on request.

Standard values for voltage and operating mode: 24 V, S2 (5%).

The devices correspond to protection class III. Electrical equipment of protection class III may be only connected to low voltage systems (PELV, SELV)(IEC 60364-4-41).

Information and remarks concerning European directives can be taken from the correspondent information sheet which is available under Produktinfo.Magnet-Schultz.com.

Please make sure that the described devices are suitable for your application. Our offers for these devices are based on the assumption of maximal 8 in an FMEA severity table, i. e. in case of malfunction of the device model as offered, there is, amongst others, no jeopardy of life or limb. Supplementary information concerning its proper installation can be taken also from the  –Technical Explanation, the effective DIN VDE0580 as well as the relevant specifications.

This part list is a document for technically qualified personnel.

The present publication is for informational purposes only and shall not be construed as mandatory illustration of the products unless otherwise confirmed expressively.

Dimension tables

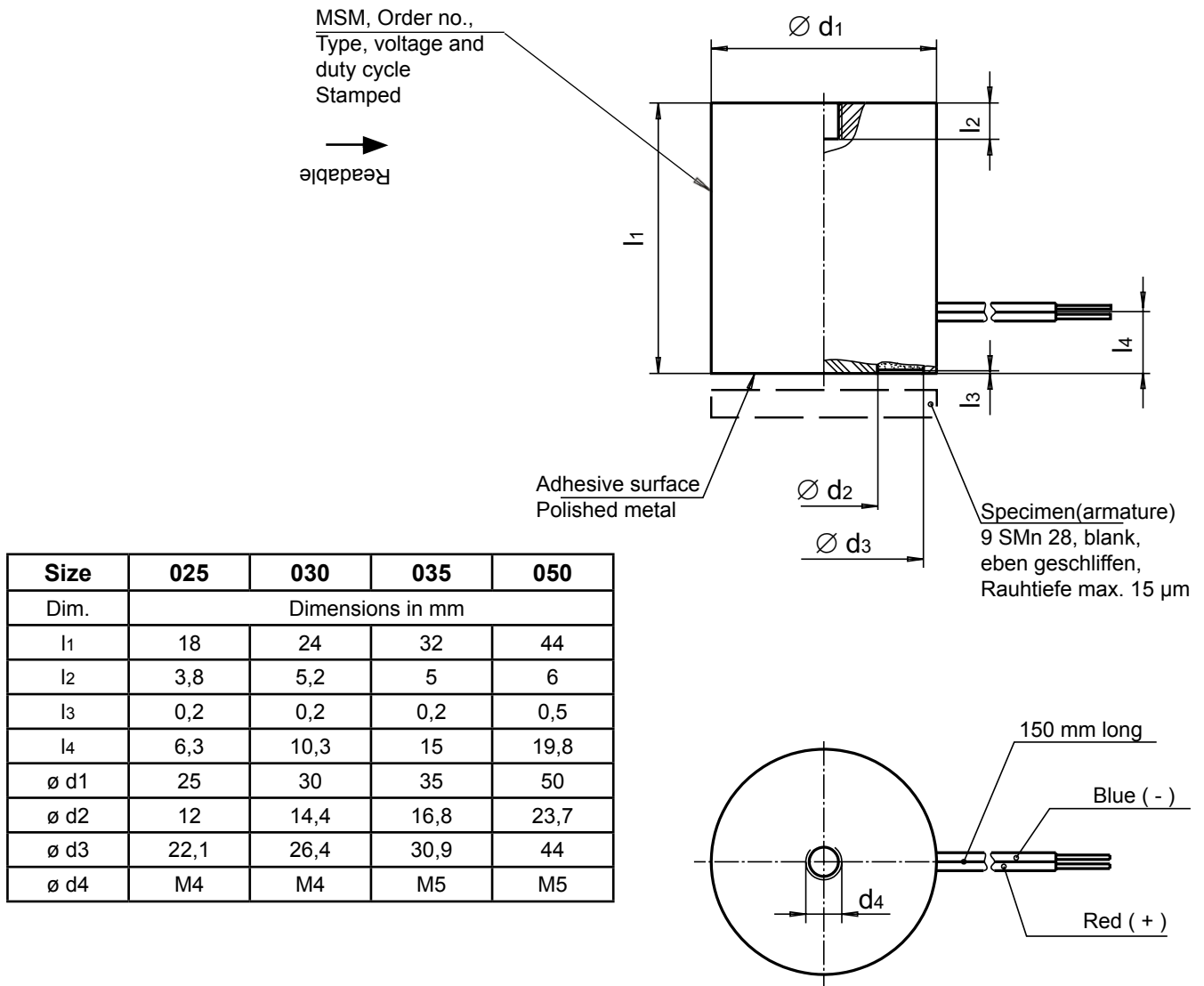
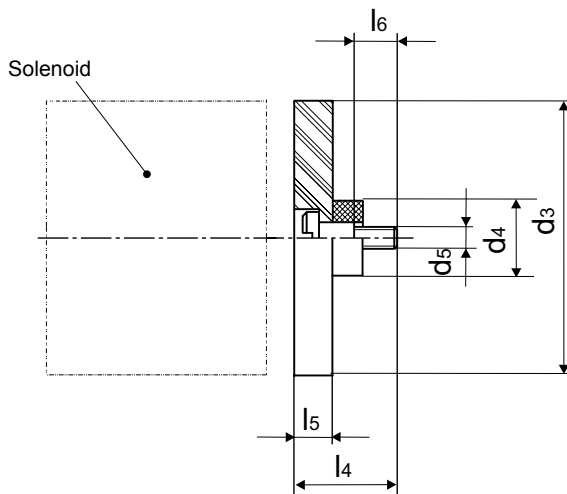

Fig. 4: Type G MP X 025 X00 B01
to G MP X 050 X00 B01

Armatures for solenoids



G Z Z E				
Size	025	030	035	050
Dim.	Dimensions in mm			
d3	25	30	35	50
d4	8	10,5	10,5	10,5
d5	M3	M4	M4	M4
l4	9,5	14	14	15
l5	3	5	5	6
l6	4,5	6	6	6

Fig. 5: G Z Z E 025 X 00 A01
up to G Z Z E 050 X 00 A01
(size 030: ... D01)

Type code

Type	Size	Suitable armature	Standard values, Voltage, duty cycle
G MP X 025 X00 B01	025	G Z Z E 025 X00 A01	24V, S2
G MP X 030 X00 B01	030	G Z Z E 030X00 D01	
G MP X 035 X00 B01	035	G Z Z E 035 X00 A01	
G MP X 050 X00 B01	050	G Z Z E 050 X00 A01	

Example

Type G MP X 050 X00 B01
Voltage == 24 V DC
Operating mode S2 (short-time duty)

Specials designs

Please do not hesitate to ask for our assistance with the solution of your application-oriented task. In order to find rapidly a reliable solution we need complete details about your application conditions. The details should be specified as precisely as possible in accordance with the relevant -Technical Explanations.

If necessary, please request the support of our corresponding technical office.